



Being safe around collaborative and versatile robots in shared spaces

Protocol

Test Mobile Robot Arm for Collision with Fixed Object (Crush)

MRO-LIE-1

The purpose of this protocol is to validate the safety skill “limit interaction energy” by measurement. Its scope is limited to mobile robot arms that used in Logistics and Manufacturing applications. In this context, the skill “limit interaction energy” is often used to protect workers from injuries caused by collisions where the mobile robot arm traps a part of the human body against a fixed obstacle. The validation of this protocol requires that the reader has a bio-fidel force and pressure measurement device available.

Readiness Level	Description
7	Protocol is published over the toolkit, under evaluation, and open for community feedback.

COVER is a community effort and values any honest feedback to our services. Please feel free to express your opinion about this protocol. [The feedback form is only one click away.](#) Thanks for making COVER even better!

Disclaimer: This protocol reflects the current and collectively developed state of the art in the validation of a specific safety skill for a collaborative robot. However, you may have to adapt the described validation procedure to be feasible for your particular application, circumstances and applicable regulations. Neither the COVER project consortium as a whole nor any individual partner of the consortium takes, therefore, any responsibility for the correctness and completeness of the validation procedure described here.



Grant agreement no. 779966

Date 2020-09-08

CONTENTS

1	Introduction	1
1.1	Scope and limitation	1
1.2	Definitions and Terms	2
2	Concept and Objectives	3
2.1	Hazardous Situations	4
2.2	Target Behavior and Metrics of the Safety Skill	4
3	Conditions	4
3.1	System	4
3.2	Sub-System	6
3.3	Environment	7
3.4	Miscellaneous	7
4	Setup	8
4.1	Test Arrangement	8
4.2	Sensing Devices	9
4.3	Data Acquisition	10
5	Procedure	10
5.1	Test Plan	10
5.2	Preparation	11
5.2.1	Setup	11
5.2.2	System Conditions	13
5.2.3	Environmental Conditions	14
5.3	Test Execution	14
5.4	Data Processing and Analysis	14
5.5	Report	16
A	Stiffness Parameter of the Human Body	17
B	Report Form	17

1 Introduction

The purpose of this protocol is to validate by measurement that the contact force and pressure, affecting the human during a collision with a collaborative robot, do not exceed the biomechanical thresholds which apply for your specific case (for instance those of ISO/TS 15066). This protocol is specifically for validating quasi-static contacts, where the robot clamps the operator, as the affected body part is spatially constrained by an obstacle and cannot move freely away from acting contact force.

Example: A mobile manipulator carrying out a pick and place task next to a human operator. A typical case of foreseeable misuse is the operator reaching spontaneously into the mobile manipulator workspace to pick up an object that slipped out of the robot gripper. In such a situation, it is likely that the mobile manipulator clamps the legs of the human due to physical constraints (obstacles) in the direction of the robot movement. Such a contact is considered as quasi-static if the contact forces saturates after 500 ms.

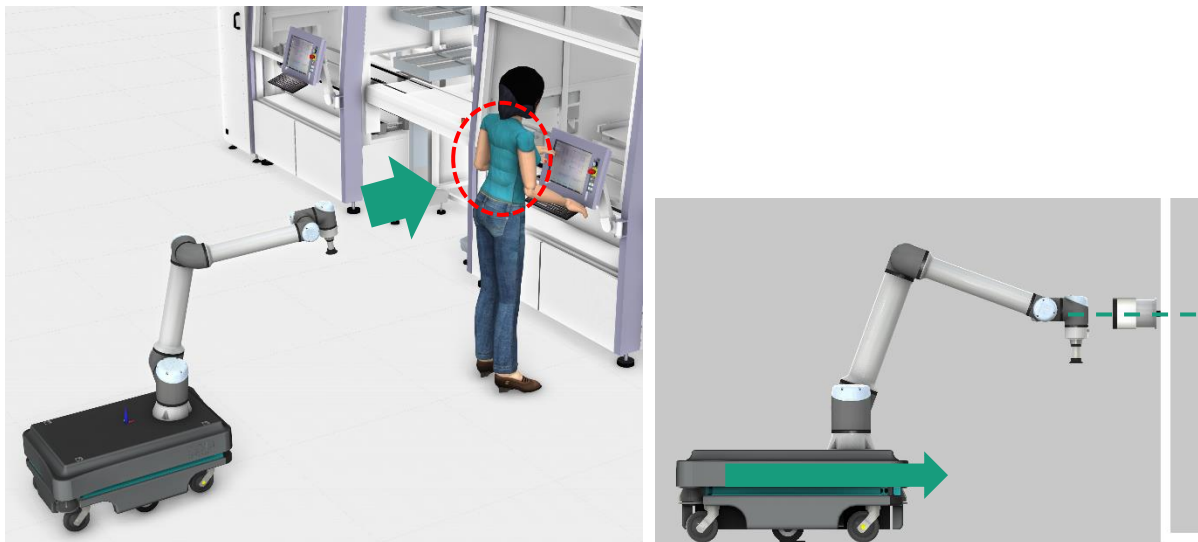



Figure 1: Exemplary situation of a clamping quasi-static contact with the manipulator of a mobile manipulator (left) and principle test setup to analyse such contacts (right)

1.1 Scope and limitation

This protocol is specifically limited to the following profile:

Skill	limit physical interaction energy
System	mobile robot arm
Sub-System	robot arm
Domain	cross-domain
Conditions	environment: indoor-factory obstacle (human body part): stationary (fixed)
Measurement Device(s)	device that mimics the biomechanical behavior (bio-fidelity) of the human body (at least of its considered part) and that can measure force and pressure

	<p>Warning</p> <p>This protocol supports users to validate the effectiveness of the skill listed in the profile above. The skill should be a technical measure of the system integrator applied to mitigate the risk of <u>one</u> potentially hazardous situation as identified in the risk assessment which the reader has to be done before using this protocol. In general, the risk assessment is a mandatory and helpful source to identify test situations and conditions relevant for a proper validation.</p>
---	---

1.2 Definitions and Terms

Industrial robot (source: EN ISO 10218-1)

Automatically controlled, reprogrammable multipurpose manipulator, programmable in three or more axes, which can be either fixed in place or mobile for use in industrial automation applications

Industrial robotic system (source: EN ISO 10218-1)

System comprising:

- Industrial robot
- End effector(s)
- any machinery, equipment, devices, external auxiliary axes or sensors supporting the robot performing its task

Collaborative operation (source: EN ISO/TS 15066)

State in which a purposely designed robot system and an operator work within a collaborative workspace.

Collaborative robot (source: EN ISO 10218-2)

Robot designed for direct interaction with a human within a defined collaborative workspace.

Collaborative Workspace (source: ISO/TS 15066)

Space within the operating space where the robot system (including the workpiece) and a human can perform tasks concurrently during production operation.

Mobile robot (source: ISO 13842:2014)

Robot able to travel under its own control

System integrator

Company or person who created the collaborative robot and brought it into productive operation. The system integrator is responsible for doing the risk assessment and must ship the collaborative robot with an instruction manual which refers to the residual risks of the robot system.

Robot operator

Person who is working with or beside the robot within the collaborative workspace.

Unintended contact

Contact refers to a state in which the robot and human are in touch and applying mechanical forces to each other. A contact is considered as unintended if the robot touches the human accidentally due to failure or misuse.

Transient contact (source: ISO/TS 15066)

Contact between an operator and part of a robot system, where the operator body part is not clamped and can recoil or retract from the moving part of the robot system. In the course of the contact force recorded over time, the transient contact phase is the part of the signal that ranges from initial contact to 500 ms thereafter.

Quasi-static contact (source: ISO/TS 15066)

Contact between an operator and part of a robot system, where the operator body part can be clamped between a moving part of a robot system and another fixed or moving part of the robot system. In the course of the contact force recorded over time, the quasi-static contact phase begins 500 ms after initial contact.

Application (source: EN ISO 10218-2)

Intended use of the robot system, i.e. the process, the task and the intended purpose of the robot system (for instance spot welding, painting, assembly, palletizing).

Collision instrument / measurement instrument

System to measure the contact forces and pressures on a collaborative robot system for identified cases of unintended and potentially hazardous contacts.

Platform tool

A tool is a device that is designed to interact with the environment. It can be a gripper, a drill, a welding torch, or any other kind of device. The platform tool is mounted on the platform.

Robot tool

The tool is a device that is designed to interact with the environment. It can be a gripper, a drill, a welding torch, or any other kind of device. The robot tool is mounted on the end effector of the robot.

Workpiece

The work piece is the physical part that the robot and/or platform are performing work on. This includes parts that are lifted by the robotic system (e.g. boxes, car doors, etc.) or parts that are worked on (e.g. parts that are welded or drilled by the robot).

2 Concept and Objectives

The concept of the verification process is to simulate a quasi-static contact with the real robot system and a measurement device that mimics the biomechanical characteristics of the human body. During the test, the robot must operate under the same conditions, as it will be in its real application. The objective of the test is to validate by measurement whether the applied safety skill “limit physical

interaction energy” prevent the robot from exceeding the applicable biomechanical limit values or not.

2.1 Hazardous Situations

Here, the term *hazardous situation* refers to a *quasi-static contact* between robot and human as introduced in Section 1. The protocol user must apply the guideline given by this document for each quasi-static contact identified by the risk assessment as a case of foreseeable and potentially hazardous misuse.

	<p>Suggestion</p> <p>The intended use and the foreseeable misuse as identified by the risk assessment can support to clarify the potentially hazardous quasi-static contacts. Typically, bending forward at the hips in the hazardous area, losing consciousness or malicious mischief/vandalism are not foreseeable misuse.</p>
---	---

2.2 Target Behavior and Metrics of the Safety Skill

The target behavior of the skill “limit physical interaction energy” is to prevent the robot from exceeding the biomechanical limit values referenced in the risk assessment.

The target metrics are values based on physical and measurable quantities. They represent a threshold that the output values of the test must not exceed to pass the test successfully. For validating the robot skill “limit physical interaction energy”, the output values are:

- Maximum collision force F_{QS} for quasi-static contact
- Maximum collision pressure p_{QS} for quasi-static contact (normal stress)

The target metrics should be determined during the risk assessment. For this validation protocol, the target metrics are limits of the output values:

- Force limit \hat{F}_{QS} for quasi-static contact (maximum allowable clamping force)
- Pressure limit \hat{p}_{QS} for quasi-static contact (maximum allowable clamping pressure)

The target metric can vary for different parts of the human, so it is crucial to ensure which metric value applies to which body part. Please report the values of the target metric for each test using the form in Annex B.

Example: Endangered Body Part and Limit Values

Body Part	Force (N)	Pressure (N/cm ²)	Stiffness (N/mm)
Forearm muscle	160	180	40
Source	ISO/TS 15066:2016		

3 Conditions

3.1 System

The term *system* refers to the robot system consisting of:

- Type of mobile platform
- Type of tool
- Type of workpiece

The protocol user must consider the specific or possible changing part of the system as system-related conditions.

Note, that there can be more than one tool or workpiece for a particular hazardous situation (occurrence of a quasi-static contact). Refer to the risk assessment identify the task-related conditions. Please report the system composition for each single test using the form in the Annex. Note that the tool and / or workpiece may change for particular hazardous situations. This applies directly to the test (at least one test per hazardous situation).

Example: System Configuration

Mobile platform	
Manufacturer	The Robot Company
Model	Mobile robot platform 10
System Configuration	Safety Package
Control Software	MoCoControl, version 2.3.1
Platform Tool	
Manufacturer	No tools on platform directly (like hook for towing)
Model	n/a
Description	n/a
Configuration	(Position / orientation on platform - insert photo here)
Workpiece	
Manufacturer	No workpiece carried (see sub-system for further details)
Model / Type	n/a
Description	n/A
Configuration	(Position / orientation on platform - insert photo here)

Besides the configuration of the robot system, the state of the robot in the moment when the quasi-static contact occurs also has a significant influence on the output values of the validation tests. The following items describe the robot state:

- Direction and magnitude of platform velocity (rotational and linear)

These conditions are part of the robot path, which is technically a time dependent sequence of states. For a proper validation test, it is necessary to establish the same robot state as the robot will have in the moment a quasi-static contact can occur, whereby the safety skill takes over control. The points of interest for the test correspond to the hazardous conditions, along the robot path, defined in the risk assessment. They are characterized by the spatial configuration of the robot and timing in relation to the whole task execution. Therefore, the risk assessment is the primary source to identify the robot state for the test.

Please report the robot state (if available) for each single test using the form in the Annex.

Example: System State

Speed	ABS	X	Y	Ψ (yaw)			
--------------	------------	----------	----------	----------------	--	--	--

Mobile platform velocity (mm/s)	250	0	250				
Mobile platform angular velocity (rad/s)				0			
Override (%)	100						

3.2 Sub-System

This protocol considers a mobile platform with a sub-system (for instance, a robotic arm).

The term *sub-system* refers to the robot system consisting of:

- Type of robotic arm
- Type of tool
- Type of workpiece

The protocol user must consider the specific or possible changing part of the sub-system as system-related conditions.

Note, that there can be more than one tool or workpiece for a particular hazardous situation (occurrence of a quasi-static contact). Refer to the risk assessment identify the task-related conditions. Please report the system composition for each single test using the form in the Annex. Note that the tool and / or workpiece may change for particular hazardous situations. This applies directly to the test (at least one test per hazardous situation).

Example: Sub-system Configuration

Robot Arm	
Manufacturer	The Robot Company
Model	cobot 10
System Configuration	Pneumatic Package Safety Package
Control Software	coControl, version 2.3.1
Robot Tool	
Manufacturer	The Tool Company
Model	cotool 20
Description	Vacuum gripper
Work piece	
Manufacturer	My Company
Model / Type	Transport box
Description	20 cm x 50 cm long, 30 cm high (x, y, z)
Configuration	x=5 cm, y=10 cm, z=0 cm (Position of the TCP in the work piece coordinate system)

Besides the configuration of the robot system, the state of the robot in the moment when the quasi-static contact occurs also has a significant influence on the output values of the validation tests. The following items describing the robot state:

- Joint configuration (position of the individual axes)
- Direction and magnitude of TCP velocity (depends on the velocities of the individual robot axes)

Both conditions belong to the robot path, which is technically a time dependent sequence of states. For a proper validation test, it is necessary to establish the same robot state as the robot will have in the moment a quasi-static contact can occur, whereby the safety skill takes over control. The points of interest for the test correspond to the hazardous conditions, along the platform path, defined in the risk assessment. They are characterized by the spatial configuration of the robot and timing in relation to the whole task execution. Therefore, the risk assessment is the primary source to identify the robot state for the test.

Please report the robot state (if available) for each single test using the form in the Annex.

Example: Sub-system State

Joint Configuration	A1	A2	A3	A4	A5	A6	A7
Axes Position (deg)	11,9	0	0	0	0	0	
Axes Velocities (deg/s)	60	30	-60	30	0	0	
Speed Robot Arm	ABS	X	Y	Z			
TCP velocity (mm/s)	250	0	250	0			
Override (%)	100						

If the mobile manipulator control system allows for simultaneous platform and manipulator motion, then the combined maximum speed of both systems must be used for further analysis. Otherwise it is sufficient to use the individual speeds as identified in previous examples.

Example: Combination of Platform and Manipulator speeds for Mobile Manipulator

Speed Platform	ABS	X	Y	Ψ (yaw)			
Velocity (mm/s)	250	0	250				
Angular velocity (rad/s)				0			
Speed Complete System	ABS	X	Y	Z	Ψ (yaw)		
TCP velocity (mm/s)	500	0	500	0			

3.3 Environment

The protocol user must consider the following environmental conditions for the validation tests:

- Obstacles (endangered part of the human body is spatially constrained and cannot move freely in the direction of the contact)

3.4 Miscellaneous

Other relevant conditions are:

- Location of the contact area on the robot structure (incl. tool or workpiece; point at which the robot is most likely to contact the human)
- Endangered body parts (parts of the human body which the robot can affect; see Section 2.2)

Use the form of Annex B to record the location and shape of the contact area on both the robot structure and the worker body.

Example: Misc. Conditions

Contact area (on robot structure)	
Location	Workpiece (Transport box), outer surface of box (20 cm x 30 cm) or edge / corner
Photo	(insert a photo here)

Contact area (on platform structure)	
Location	Lower side of the mobile platform (bumper surface)
Photo	(insert a photo here)

Report the endangered body part next to the limit values. Add to each body part its stiffness parameter and the source of the limit values (see example in Section 2.2). Note that there is a relation between shape of the contact area and the stiffness of the body part. Note that the stiffness parameter must correspond with the limit values, meaning the affected body part has the stiffness only under a force equal to the limit value. Annex 0 summarizes some stiffness parameters of the human body.

4 Setup

4.1 Test Arrangement

The following sensors are required for doing the test:

- Load-cell for force measurement over time
- Foil sensor for pressure measurement over time

The load-cell must be part of an instrument that mimics the biomechanical characteristics of the human body or at least of the endangered body parts. Figure 2 depicts the general design of such a device. It consists of an impactor attached to a changeable spring. Linear guides ensure that the impactor can move only in the effective direction of the spring. The spring is further attached to the load-cell which is rigidly connected to the instrument housing. A soft damping material covers the top side of the impactor. The combination of damping material and spring must realize the same biomechanical characteristics as the considered part of the human body has, as defined in Annex A. The foil sensor for pressure measurement is on the top of the damping material.

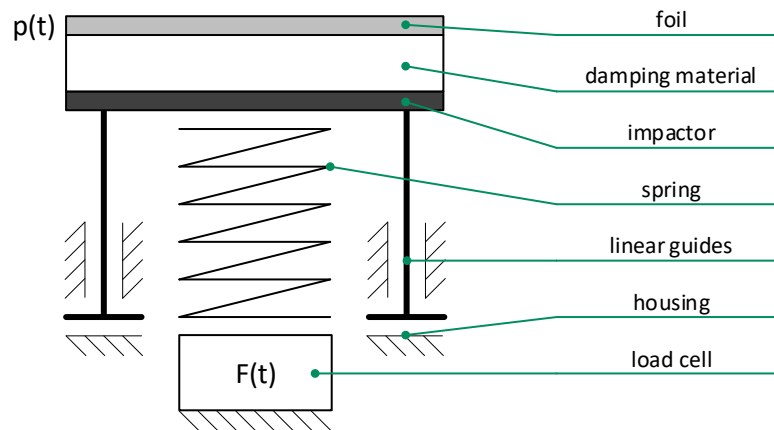

Figure 2. General design of the collision instrument

4.2 Sensing Devices

The load cell for measuring the contact force must fulfill the following requirements:

	Minimum	Recommended
Number of axes	1	1
Calibrated range	0 ... 300 N	0 ... 1000 N
Relative error (linearity)	<2%	<0.5%

Table 1. Requirements for load cell (sensor for measuring the contact force)

The foil sensor for measuring the contact pressure (normal stress within the contact area) must allow for continuous measurement (pressure over time). Therefore, the general sensor structure should contain a certain number of separate force cells (or similar) arranged in a matrix. The material, which supports the sensor matrix, must be flexible enough to bear the deformations of the damping material lying below the foil sensor. Moreover, the foil sensor must fulfill the following requirements:

	Minimum	Recommended
Calibrated range	500 N/cm ²	750 N/cm ²
Density (sensor cell per area)	4 cm ⁻²	16 cm ⁻²
Relative error (linearity)	<20%	<10%

Table 2. Requirements for foil sensor (sensor for measuring the pressure within the contact area)

Note 1: It may be necessary to equilibrate and calibrate the foil sensor before using it. This protocol cannot give any guideline to prepare the foil sensor properly, because the procedure depends significantly on its specifics and measurement principle. Refer to the documentation (datasheet or manual) of the manufacturer.

Note 2: Some foil sensors allow to adjust the measurement sensitivity. Use always the highest possible sensitivity so that the result is still within the measurement range. The sensitivity is too high if the signal of at least one measurement cell of the foil saturates.

Note 3: Use only foils whose sensitive area is slightly larger than the expected contact area.

Use the form in Annex B to report the capabilities of both sensors used for the validation.

Example: Sensors

Feature	Force Sensor	Pressure Sensor
Manufacturer and type	Sensor Company, PE 1000	Sensor Company, Foil 750
Calibrated range	1000 N	750 N/cm ²
Relative error (linearity)	<0.25%	<7.5%
Miscellaneous	Number of axes: 1	Density: 20 cm ⁻²

4.3 Data Acquisition

Required essentials for data acquisition:

- Computer for measurement control
- All devices and software (running on the computer) that are necessary to control the sensing devices and to record their signals (incl. data logger, charge amplifier, etc.)

Note: The manufactures of the commercially available measurement systems provide usually a software to control their devices and to analyze the results. Please ensure that you have access to such software, especially for your particular device. It is likely that there are separate tools for force and pressure measuring. In this case, run both tools in parallel.

Data acquisition for all signals (force and pressure) must comply with the following requirements:

	Minimum	Recommended
Sampling frequency	2,000 Hz	10,000 Hz
ADC resolution	12 bit	16 bit
Time to contact	5 s	10 s

Table 3. Requirements for data acquisition

Time to contact refers to the minimum duration lasting from starting the measurement until the time the contact force clearly rises. In case one sensor cannot fulfill the minimum requirements, please configure the sensor to its highest property values. Please record the applied configuration using the form in Annex B.

Example: Acquisition Configuration

Feature	Force Sensor	Pressure Sensor
Sampling frequency	10,000 Hz	1,800 Hz
ADC resolution	16 bit	8 bit
Time to contact	10 s	10 s

5 Procedure

5.1 Test Plan

The test plan is a summary of all situations, which the risk assessment identified as hazardous due to physical contact between robot and robot operator, incl. all combinations of applicable conditions. Therefore, the test plan provides a detailed summary which tests are necessary to validate the skill for the considered application.

The protocol user must test each quasi-static contact as identified by the risk assessment as potentially hazardous (see Section 2.1). In the sense of testing, this means to provoke a quasi-static contact between the robot and a proper measuring instrument (see Section 4.1 and 4.2). The purpose of the test is to prove whether the robot exceeds the metrics or not (see Section 2.2).

According to Chapter 3, the protocol must consider the following conditions:

- Main system (mobile platform)
 - Type of platform
 - Type of tool
 - Type of workpiece
 - Joint configuration
 - Direction and magnitude of platform velocity
- Sub-system (robot arm)
 - Type of robot
 - Type of tool
 - Type of workpiece
 - Joint configuration
 - Direction and magnitude of robot velocity
 - (if necessary) Sum of magnitudes of platform and robot velocity
- Environment
 - Obstacles
- Miscellaneous
 - Location and shape of the contact area on the robot structure
 - Endangered body parts

For the validation test, it is necessary to measure all possible combinations of conditions which are applicable for the considered hazardous situation. Therefore, a single combination corresponds in conjunctions with the considered hazardous situation to a particular test case. It is recommended to prepare a list that organizes all hazardous situations and applicable conditions row wise. Each row represents a particular test case that the protocol user must run and report using the form in Annex B. The protocol user should repeat each test three times.

5.2 Preparation

5.2.1 Setup

Measurement Equipment

- Connect all sensors to their loggers and the loggers to your computer. Make sure that you can start and stop the recording of all signals from your computer and that the acquisition works exactly as configured.
- Configure the parameter of the data acquisition within the range specified in Section 4.3.

Collision Instrument

- Install the spring and apply the damping material to the impactor (see test plan). Make sure that the characteristics of the used combination fits to the stiffness of the endangered body part (see Section 2.2).

- For each test, attach the collision instrument to a stiff frame that holds it in place during the test and does not deform significantly under the contact force. For instance, use aluminum profiles to create an appropriate support.
- For each test, orient the collision instrument perpendicular to the moving direction the contact point on the robot surface has in the workspace right before touching the instrument (Figure 3).

Pressure Sensor

- To avoid damage to the pressure foil, cover it with a PTFE foil (thickness below 50 μm).
- Rough surfaces can result in small regions of significant peak pressures. To avoid them, use a microfiber cloth (thickness below 500 μm).
- Make sure that the sensitive area of the foil covers the contact area completely.
- Use rubber band to attach the foil to the impactor of the collision instrument. Ensure that the rubber band does not run over the sensitive area of the pressure foil.

	<p>Warning</p> <p>The applied combination of spring and damping material must simulate the response behavior of the body part to be tested. In order to select the right combination, it may also be necessary to consider the shape of the contact area on the robot surface.</p>
--	---

	<p>Warning</p> <p>The stiffness of the instrument support must be 20x higher than the stiffest spring used for all tests.</p>
--	--

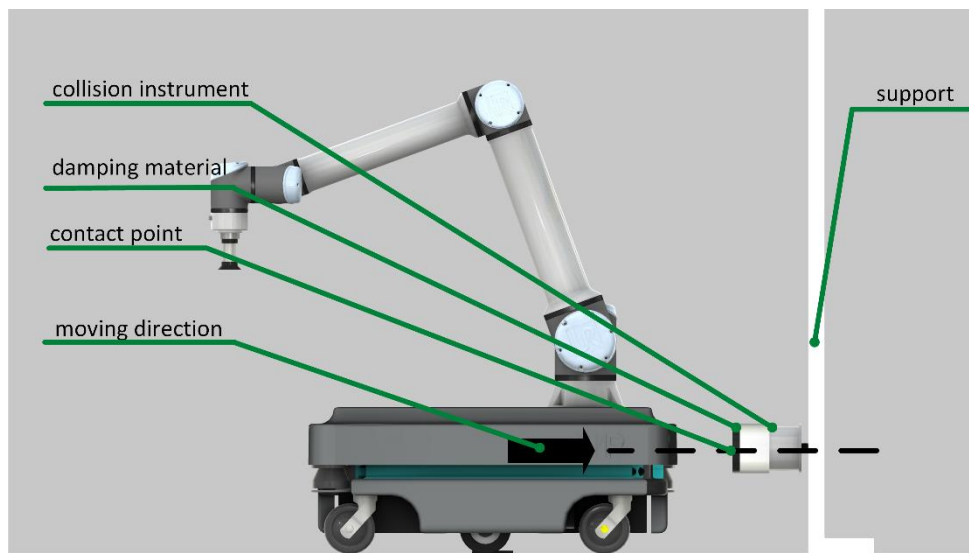

Figure 3. Schematic drawing of the setup for testing collisions with the mobile platform

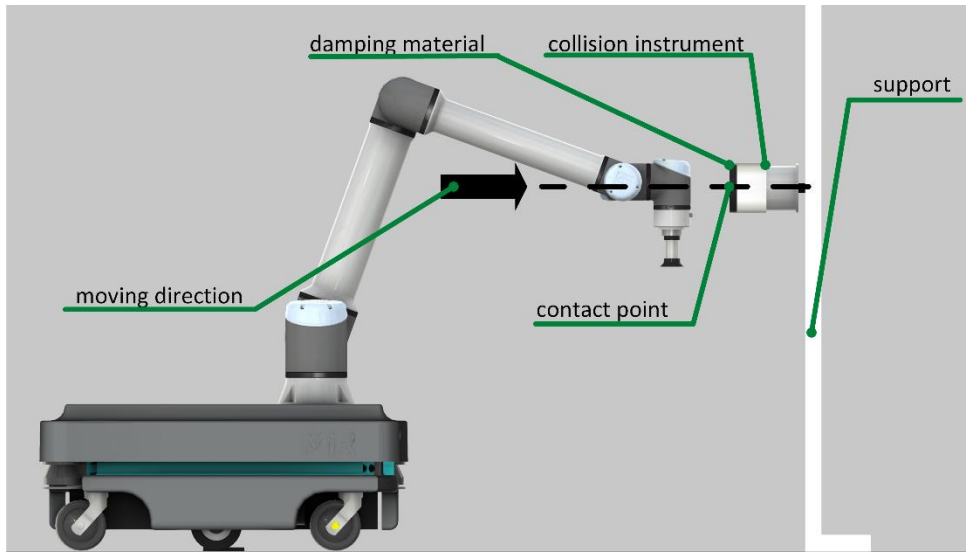

Figure 4. Schematic drawing of the setup for testing collisions with robot

Use the form in Annex B to record the applied spring and damping material:

Example: Configuration of the Collision Instrument for Back and Shoulder

Spring rate (N/mm)	35
Hardness of damping material	30 (Shore A hardness)
Thickness	

5.2.2 System Conditions

The protocol user must set up the robot according to the configuration that will be used for the specific application. This includes at least the following steps:

- Switch on the robot one hour before beginning the tests (warm-up phase).
- Install all tools and provide all workpieces the robot will use or handle later in the application.
- Install the final program that contains all movements and actions the robot will execute in the application.
- Configure all available safety-functions.

	<p>Warning</p> <p>The safety configuration, and therefore the safety skill, is often a part of the robot program or inseparably connected with it. For this reason, the protocol user must not change the robot program after successfully completing the validation. It is highly recommended to store a backup of the positively tested program and to lock the robot control unit so that only authorized people can modify the program or the safety configuration. Any modification to the program requires a new validation of the safety skill.</p>
---	---

Note: If the robot has no safety functions to monitor its states (such as individual joint or platform speeds), the protocol user must perform all tests at maximum speed, even if this speed is not required for the application.

5.2.3 Environmental Conditions

There are no environmental conditions that the protocol user must explicitly establish for the test. However, it is highly recommended to run the tests in the same environment in which the robot system will operate later.

5.3 Test Execution

Apply the following steps for each test case:

- Move the robot slowly to the point where the quasi-static contact can occur (see test plan or risk assessment).
- Check if the measuring instrument is in the right position and orientation. It is in the right position if the robot almost touches it when reaching the point of interest (contact point) along its path. It is in the right orientation, if the moving direction of the contact point is perpendicular to the impactor plate of the collision instrument (see Section 5.2.1). In case position and orientation of the instrument are not OK, adjust both until they are.
- Move the robot backwards along the path. Choose on this path a proper start position from which the robot has enough time to accelerate to its programmed speed before reaching the point of interest.
- Take a photo of the test situation (recommended).
- Start the measurement systems.
- Start the robot movement.
- After the robot hits the collision instrument and has stopped, take another photo of the situation (recommended).
- Save the recorded signals.
- Release the robot and/or platform by moving it under manual control.
- Rearrange the pressure foil and damping material on the impactor (if slipped during the collision)
- Carry out at least three tests (see Section 5.1).

5.4 Data Processing and Analysis

After finishing the last repeat, there should be three results from three test available. It is recommended to start with filtering each signal right after recording. Since the pressure signal is technically a sequence of images, it is necessary to apply an additional image filter that reduces the noise across all pixels. The requirements for both filter types are:

Signal Filter (for all signals)	Minimum	Recommended
Signal filter type	1 st order Butterworth low pass	4 th order Butterworth low pass, zero-phase
Cut-off frequency	200 Hz	200 Hz
Image Filter (for pressure only)	Minimum	Recommended
Image filter type	Average filter	Gaussian filter
Standard deviation	N/A	$\sqrt{2/\pi}$

Table 4. Requirements for signal and image filtering

For image filtering, it is highly recommended to use a software that has such filters included. In general, the manufacturers of the pressure measurement system should provide such tools in combination with the sensor. Use the form in Annex B to record the applied filter configuration.

Example: Acquisition Configuration

	Force Sensor	Pressure Sensor
Signal filter type	4 th order Butterworth low pass, zero-phase	4 th order Butterworth low pass, zero-phase
Cut-off frequency	200 Hz	200 Hz
Image filter type		Gaussian filter
Standard deviation		$\sqrt{2/\pi}$

After filtering, offset compensation can be achieved by calculating the average value that each signal has within a time window from 0.5 s to 1.5 s (0 s marks start of signal recording). Afterwards, subtract the average values from all values of their respective signals. Figure 5 illustrates the procedure for the force signal.

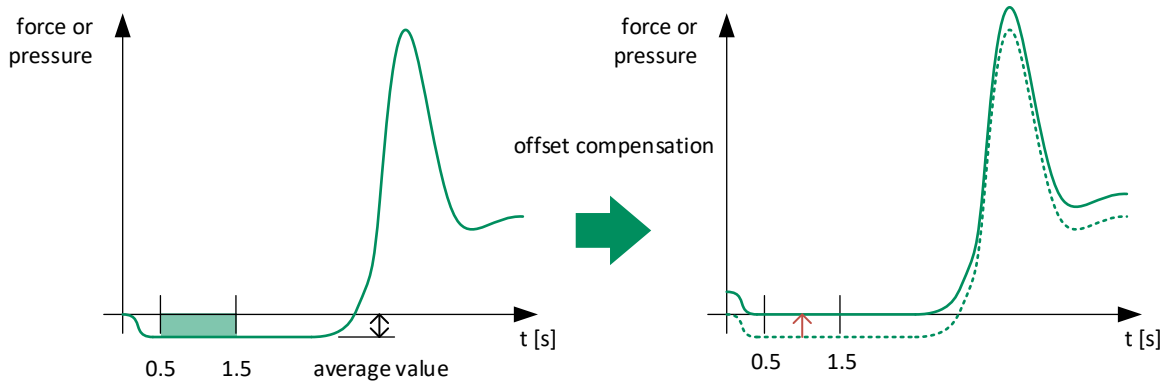

Figure 5. Procedure for Offset Compensation

Right after all signals are processed, the protocol user must determine the maximum force and pressure values from each signal. Make sure that the maximum lies within a time windows ranging from 0.5 s until the end of the contact, while 0 s marks the start of the contact (see Figure 6). Record the maximum values in the form which is available in Annex B.

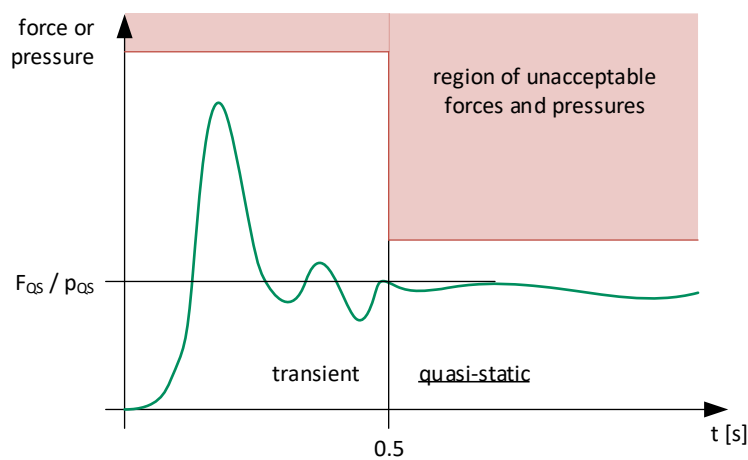



Figure 6. Representation of acceptable forces and pressures

	Suggestion
	<p>To minimize the efforts necessary for doing pressure measurement, it is recommended to do one force measurement first. If the maximum contact force of this measurement is significantly below the applicable limit value, repeat the test three times including pressure measurement. If the maximum force already exceeds the force limit, the protocol user can omit pressure measurement.</p>

Example: Result from Data Analysis

	Test 1	Test 2	Test 3	MAX
Maximum force (N)	159	145	165	165
Maximum pressure (N/cm ²)	34	39	41	41

If the highest maximum of all three tests exceeds the applicable limit value, the safety skill fails the test. If not, it passes the test. In the case the robot fails the test, it is recommended to modify the robot program (for instance reducing the speed) and to start over with the validation process. Other options could be a modification of the safety configuration or conditions.

5.5 Report

Use the form in Annex B to report all conditions and results of the tests. After finishing the validation successfully (all tests passed), add the forms to your risk assessment. They are the proof that the applied safety skill is effective and gives the expected protection to robot operator working beside the collaborative robot. Use the last section in the form to record the overall result of the test (passed / failed).

Example: Summary

	Test 1	Test 2	Test 3	Test Pass
Pass	yes	yes	no	no

A Stiffness Parameter of the Human Body

See Table 5 to determine the right combination of a damping material and spring to mimic the biomechanical characteristics of various body regions.

Note 1: You can neglect Table 5 if you have other and also reliable data for configuring the spring-damping characteristics of the collision instrument. However, record the source of your data in the report forms.

Note 2: Data given in Table 5 are subject to modifications.

Table 5. Combinations of damping material and spring to mimic the biomechanical characteristics for various body regions (source: DGUV FBHM 080)

Body region	Damping material hardness (shore A)	Damping material thickness (mm)	Spring (N/mm)
Skull and Forehead	70	7	150
Face			75
Hand and Finger			75
Neck			50
Forearm and Wrist			40
Chest			25
Pelvis			25
Lower Leg	30	14	60
Upper Leg and Knee			50
Back and Shoulder			35
Upper Arm and Elbow			30
Belly	10	21	10

B Report Form

Use the form on the next page to record the data for each test.

Test ID / Test no	
Hazard ID	
Description	
Photo	

Setup

Sensors

Feature	Force Sensor	Pressure Sensor
Manufacturer and type		
Calibrated range		
Relative error (linearity)		
Miscellaneous		

Acquisition Configuration

Feature	Force Sensor	Pressure Sensor
Sampling frequency		
ADC resolution		
Time to contact		

System Configuration

Mobile Platform	
Manufacturer	
Model	
System Configuration	
Control Software	
Platform Tool	
Manufacturer	
Model	
Description	
Work Piece	
Manufacturer	
Model / Type	
Description	
Configuration	

Sub-system Configuration

Robot Arm	
Manufacturer	
Model	
System Configuration	
Control Software	
Robot Tool	
Manufacturer	
Model	
Description	
Work piece	
Manufacturer	
Model / Type	
Description	
Configuration	

Test Specifics

System State

Speed Platform	ABS	X	Y	ψ (yaw)			
Velocity (mm/s)							
Angular velocity (rad/s)							
Joint Configuration	A1	A2	A3	A4	A5	A6	A7
Axes position (deg)							
Axes velocities (deg/s)							
Speed Robot Arm	ABS	X	Y	Z			
TCP velocity (mm/s)							
Override (%)							
Speed Complete System	ABS	X	Y	Z	ψ (yaw)		
TCP velocity (mm/s)							

Misc. Conditions

Contact Area (on robot structure)	
Location	
Photo	

Endangered Body Part and Limit Values

Body Part	Force (N)	Pressure (N/cm ²)	Stiffness (N/mm)
Source			

Configuration of the Collision Instrument

Spring rate (N/mm)	
Hardness of damping material	

Test Result

Result from Data Analysis

	Test 1	Test 2	Test 3	MAX
Maximum force (N)				
Maximum pressure (N/cm ²)				

Summary

	Test 1	Test 2	Test 3	ALL yes
Pass				